



目录 CONTENTS

钢制销合链

Steel Pintle chains

钢制销合链 Steel Pintle chains.....	1
钢制销合链附件 Steel Pintle chains - Attachments.....	2-5

钢制销合链 Steel Pintle chains



钢制销合链 Steel Pintle chains

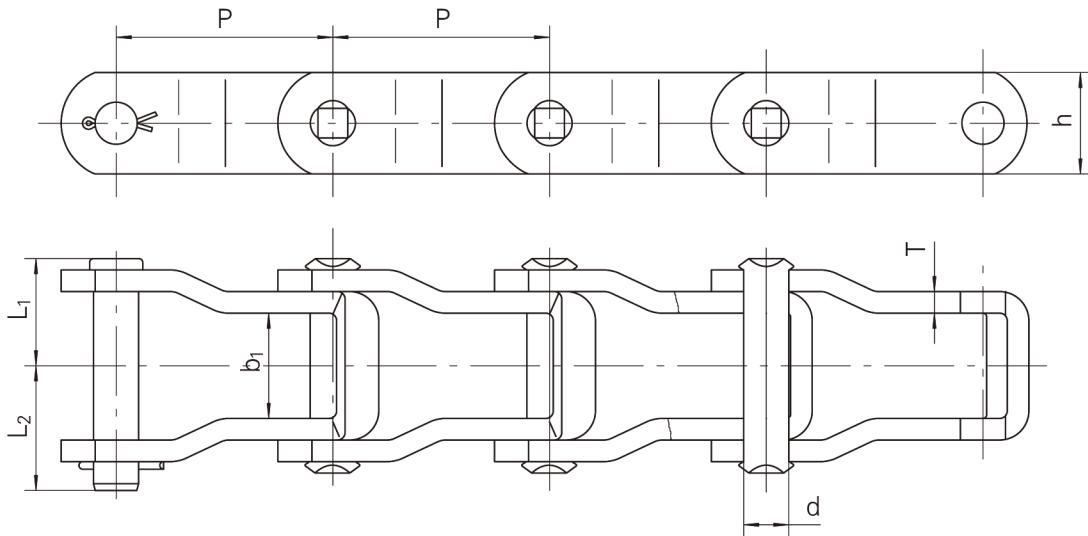

链号	节距	窄端内宽	销轴			链板		最小抗拉强度	平均拉伸强度	许用工作载荷	每米重量
Chain No.	Pitch	Inside width at narrow end	Pin			Plate		Ultimate tensile strength	Average tensile strength	Maximum recommended working load	Weight per meter
	P	b_1	d	L_1	L_2	h	T	$F_u(\text{min})$	Q_0	kN	q
	mm	mm	mm	mm	mm	mm	mm	kN	kN		kg/m
D205	31.75	9.4	5.08	11	13.4	11.9	2.1	18	21.8	2.5	0.62
662	42.27	22.9	7.16	20.45	23.25	18.3	3.2	42.5	49.8	7.6	1.66
662H	42.27	22.9	7.16	21.25	24.05	20.4	3.6	48.9	52	7.8	2.04
662HD	42.27	22.9	7.92	22.65	25.55	22.23	4.3	60	65.8	9.3	2.66
667X	57.15	26.3	11.1	25.55	28.75	23.8	4.3	88.9	96.5	13.4	2.91
667XH	57.15	26.5	11.91	29	32.3	26.8	5.7	124.5	138	21.4	4.31
D667K	57.15	26.5	11.1	27.7	30.9	26.8	5.1	106.8	123	16.7	3.80
667J	57.15	26.5	9.52	25.55	28.75	23.8	4.3	86.5	95	13.1	2.80
667H	58.75	25.4	7.92	21.65	24.45	22.23	3.2	52.1	57.4	8.5	1.85
88K	66.27	26.5	11.1	27.7	30.9	26.8	5.1	106.8	123	17.8	3.60
D88C	66.27	31.5	12.7	32.65	35.65	28.58	6.4	152	169	26.7	5.25
308C	78.1	32.5	15.88	38.05	41.95	38.1	8	200	222	35.6	8.44

钢制销合链附件 Steel Pintle chains – Attachment

BRH附件
BRH Attachment

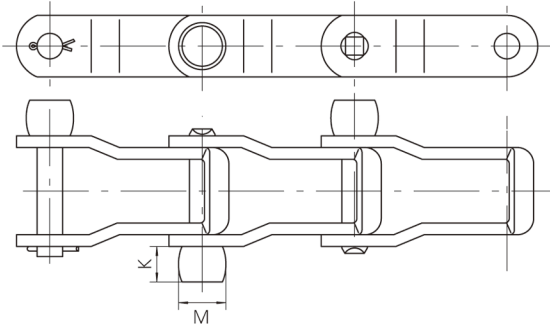

附件号	链号	K	M
Att. No.	Chain No.	mm	mm
BRH	88K	15.5	20.65

G38附件
G38 Attachment

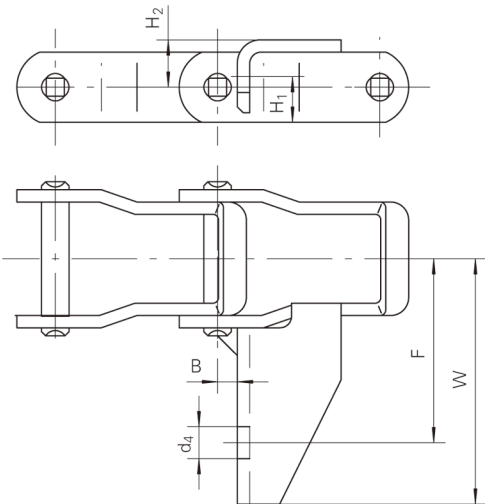

附件号	链号	H ₁	H ₂	E	B	F	W	d ₄
Att. No.	Chain No.	mm	mm	mm	mm	mm	mm	mm
G38	662	11.9	12.35	28.6	5.2	49.2	59.5	8.33

G50附件
G50 Attachment

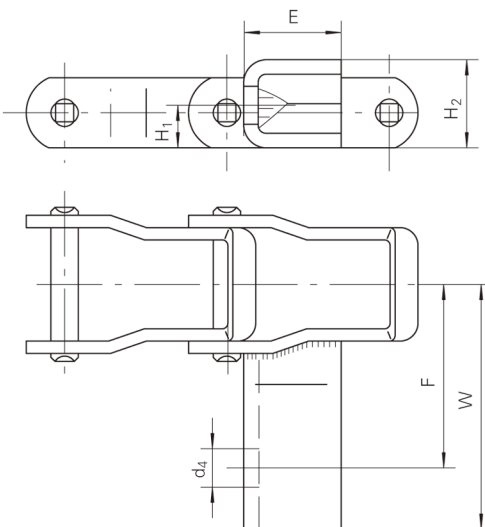

附件号	链号	H ₁	H ₂	E	F	W	d ₄
Att. No.	Chain No.	mm	mm	mm	mm	mm	mm
G50	662	11.1	22.2	25.4	39.7	54.8	9.91
	662HD	11.115	22.23	25.4	45.8	65.5	9.92

钢制销合链附件 Steel Pintle chains – Attachment

HB附件
HB Attachment

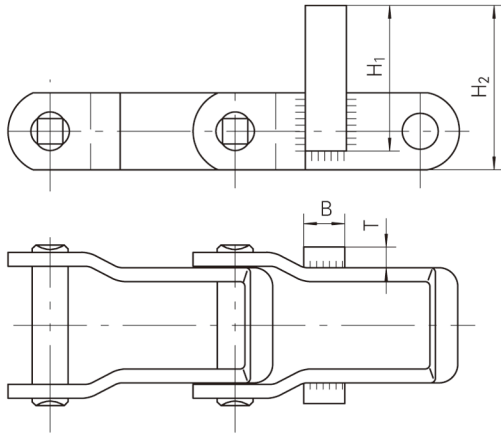

附件号	链号	H ₁	H ₂	B	T
Att. No.	Chain No.	mm	mm	mm	mm
HB	667X	45	50.8	12.7	6.4

ASSY附件
ASSY Attachment

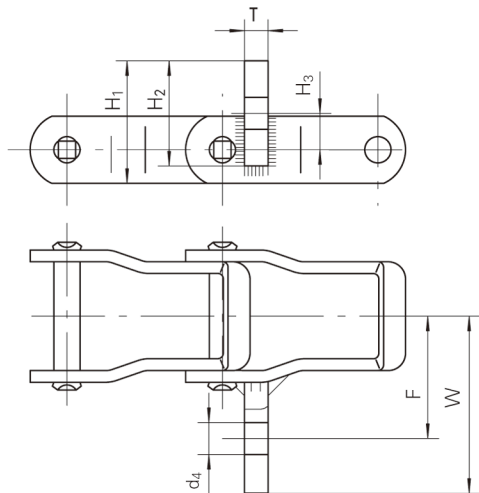

附件号	链号	H ₁	H ₂	H ₃	B	F	W	d ₄	T
Att.No.	Chain No.	mm	mm	mm	mm	mm	mm	mm	mm
ASSY	662	24.2	28.6	9.9	6	33.35	48.25	8.7	6.4

AS ASS AG K1S K1SA附件
AS ASS AG K1S K1SA Attachment

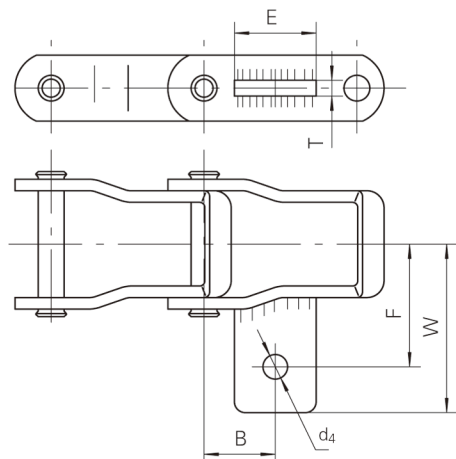

附件号	链号	F	W	B	E	d ₄	T
Att. No.	Chain No.	mm	mm	mm	mm	mm	mm
AS	662	34.9	47.6	19.5	22	6.8	4.5
	662H	34.9	47.6	19.5	22	6.8	4.5
	667H	51.6	66	29.3	28.6	8.64	6.4
	667J	51.6	68	28.55	28.5	8.4	8
	667XH	51.6	69.85	24.7	31.8	9.9	9.5
ASS	667X	51.6	68	28.55	28.5	10	8
	667H	51.6	66	29.3	28.6	9.9	6.4
	D667K	51.6	68.3	24.7	31.8	11.5	9.5
AG	667K	65	85	24.7	31.8	11.5	9.5
K1S	667XH	47.63	59.1	24.7	28.6	9.5	6.4
	D88C	51.6	63.9	28	28.6	9.5	6.4
K1SA	D88C	51.6	72.2	33.9	31.8	10	9.5

钢制销合链附件 Steel Pintle chains – Attachment

A5附件
A5 Attachment

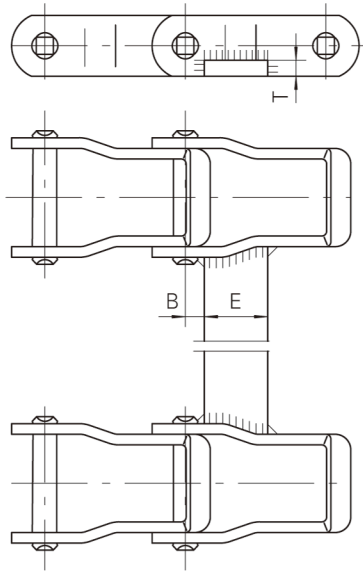

附件号	链号	E	T	B
Att. No.	Chain No.	mm	mm	mm
A5S1	662	19.05	4.8	5.72
A5S2		19.05	6	5.72
A5M1		25.4	4.8	4.87
A5M2		25.4	6	4.87
A5M3		25.4	6.4	4.87
A5S1	667X	25.4	6.4	15
A5M1		38.1	6	8.85
A5M2		38.1	6.4	5
A5M3		38.1	9.5	2
A5M4		38.1	12.7	2
A5S1	667XH	30	6	16
A5M1		38.1	9.5	2.5
A5M2		38.1	12.7	2.5
A5S1	667K	38.1	8.5	8.85

G31.8 G36 附件
G31.8 G36 Attachment

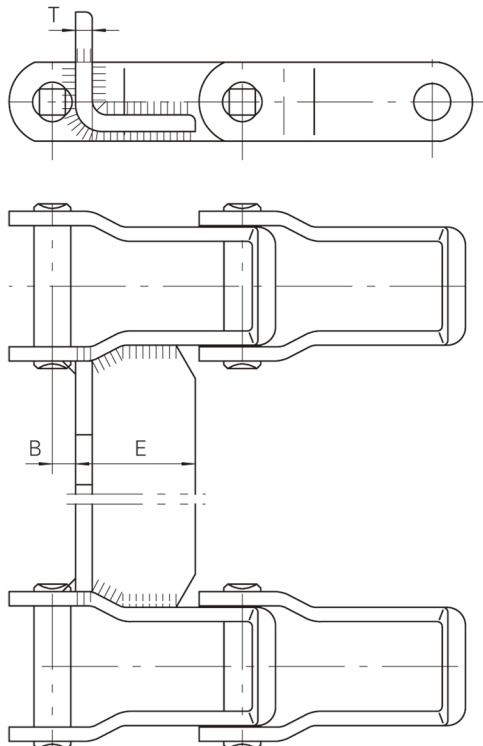

附件号	链号	E	T	B
Att. No.	Chain No.	mm	mm	mm
G36	667H	36	5	6
G31.8	667X	31.8	5	7
G36		36	5	7

钢制销合链附件

Steel Pintle chains – Attachment

SHB附件
SHB Attachment

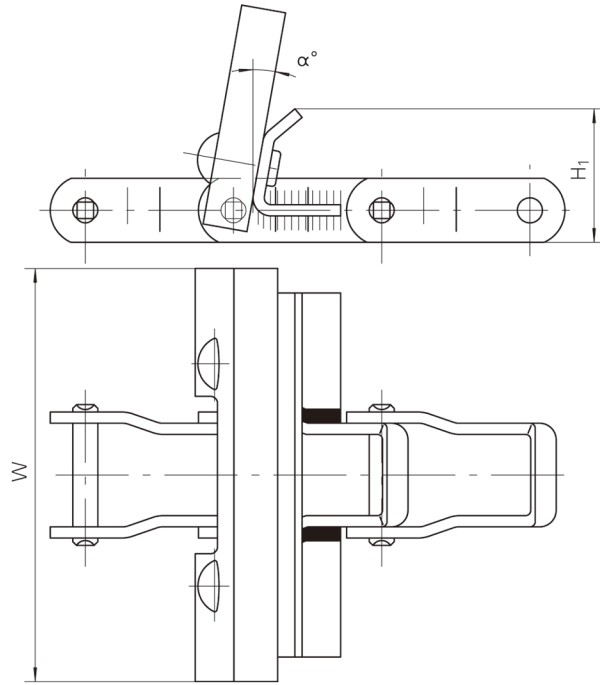

附件号	链号	W	H ₁	α
Att. No.	Chain No.	mm	mm	mm
SHB	662	285.8	38.1	10°

F12M附件
F12M Attachment

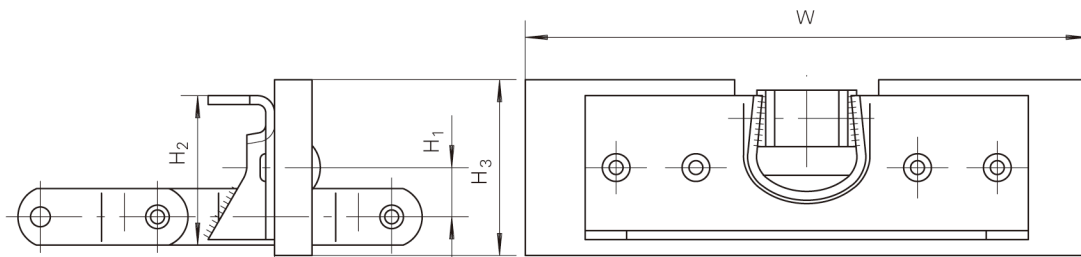

附件号	链号	W	H ₁	H ₂	H ₃
Att. No.	Chain No.	mm	mm	mm	mm
F12M	662	285.8	17.8	54	63.5
	662H	203.2	17.8	54	63.5
	667H	304.8	16.9	54	63.5